

ITD Global Conference on Taxation of SME

Identifying and Registering SME and Methods to Reduce the Informal Economy

**The Brazilian Experience**



**Receita Federal**

*Jorge Antonio Deher Rachid*  
*Federal Revenue & Customs Secretary*



Buenos Aires, October 17 – 19, 2007

# Contents

The Context

Identifying & Registering  
SME

Reducing Informality

Conclusion



## BRAZIL



- Strong administrative decentralization for 27 states and over 5.5 thousand municipalities
- Multiple tax authorities at federal, state and local levels
- Population of 189 million
- GDP of USD 1.07 trillion (2006)
- Area of 8.5 million of Km<sup>2</sup>



## Brazilian Customs & Tax Administration

### *“RECEITA FEDERAL DO BRASIL”*

- Integrates...
  - ✓ Internal revenues
  - ✓ Social security contributions
  - ✓ Customs
- 65% of total brazilian tax collection
- Budget: USD 3.1 billions
- 32 thousand employees



## Compliance costs reduction and simplification

1. Intensive use of ICT
2. Taxpayer orientation
3. Integration and cooperation with other public entities



## Intensive use of ICT (examples)

- Virtual Tax Centre (e-CAC)
  - Electronic payments
  - Electronic filling tax returns and help software
  - offers 100 different services while others are coming up
  
- Public Electronic Register System (SPED)
  - Electronic bookkeeping register
  - Electronic tax register
  - Electronic invoices



# @-CAC

*A Receita Federal  
sempre que  
você precisar !*

O e-CAC inaugura uma nova era na prestação de serviços da Receita Federal. O contribuinte, agora, pode ter acesso a qualquer hora e lugar a serviços que, antes, eram prestados apenas nas unidades físicas da Instituição.



**SISTEMA PÚBLICO  
DE ESCRITURAÇÃO DIGITAL**

# Certificação Digital



# NF



# Nota Fiscal Eletrônica



Ministério da Fazenda

[www.receita.fazenda.gov.br](http://www.receita.fazenda.gov.br)



Receita Federal



# Receita Federal do Brasil

**Bem-vindo à Receita Federal do Brasil**  
A Lei nº 11.457 de 2007 criou a Receita Federal do Brasil, unificando as atribuições da Secretaria da Receita Federal e da Secretaria da Receita Previdenciária.

## Declaração do Imposto de Renda Pessoa Física - DIRPF 2007

Programas e orientações para preenchimento e entrega da declaração.

**Atenção:** Terminou às 20 horas, horário de Brasília, de 30/4/2007, o prazo para entrega da Declaração de Imposto de Renda Pessoa Física 2007, sem o pagamento de multa por atraso.

## Agendamento de serviços na Secretaria da Receita Federal por meio da Internet

Para proporcionar maior comodidade ao cidadão e buscando otimizar o atendimento nas unidades de atendimento da Receita Federal, foi disponibilizado o agendamento de serviços via Internet para pessoas físicas e pessoas jurídicas.

## DIPJ - Declaração de Informações Econômico-fiscais da Pessoa Jurídica

## DCTF - Ato Declaratório Executivo dispõe sobre o preenchimento da DCTF

## Consulta Fontes Pagadoras - Consulta a Rendimentos e IRRF

Novo serviço que permite consulta aos Rendimentos e IRRF (Imposto de Renda Retido na Fonte) informados pelas Fontes Pagadoras, para contribuintes com certificado digital.

## Alíquota Efetiva do IRPF 2007 - Simulador

Simulador para cálculo do imposto de renda mensal e anual.

## DereX - Declaração sobre a Utilização dos Recursos em Moeda Estrangeira Decorrentes do Recebimento de Exportações

Instrução Normativa SRF nº 726 de 28.02.2007 dispõe sobre operações de câmbio e a manutenção de recursos no exterior...

## IRPF - Extrato Simplificado do Processamento

Para esta consulta é obrigatória a utilização do número do recibo de entrega da declaração.

**NOTÍCIAS**  
> Mais notícias

**AGENDA TRIBUTÁRIA**  
Maio 2007

D	S	T	Q	Q	S	S
		01	02	03	04	05
06	07	08	09	10	11	12
13	14	15	16	17	18	19
20	21	22	23	24	25	26
27	28	29	30	31		

> Diário  
>> Mais detalhes...

**CADASTROS**

**ALÍQUOTAS E TABELAS**

**TAXA DE JUROS SELIC**  
Fev/2007 : 0,87%  
Mar/2007 : 1,05%  
Abr/2007 : 0,94%  
>> Mais detalhes...

**TAXA DE JUROS - TJLP**  
Jan-Mar/2007: 0,5417%  
Abr-Jun/2007: 0,5417%  
>> Mais detalhes...

**PESQUISA DE SATISFAÇÃO**  
O que você achou desta página?

**LINKS**



> Atualize sua página...

**e-CAC**  
Centro Virtual de Atendimento ao Contribuinte  
Serviços online para você.

**e-CNPJ**  
Certificados Digitais  
Conheça mais

**CADASTRO SINCRONIZADO NACIONAL**

**SPED SISTEMA PÚBLICO DE ESCRITURAÇÃO DIGITAL**

Visite o sítio **MEMÓRIA RECEITA FEDERAL**  
e conheça um pouco da nossa história...

**AVISOS**

Obrigatoriedade de Apresentação da DCTF Mensal  
>> Mais Avisos

**NOVIDADES**

> Legislação  
> Leilões: Ceará | Mato Grosso do Sul | Paraná | Rio Grande do Norte | São Paulo

**OUTROS DESTAQUES**

> Sistema Harmonizado 2007  
> Contabilidade  
> Cidadania Fiscal  
> Estudos Econômico-Tributários

## Orientation to taxpayers

- ◆ 532 branches for taxpayers
- ◆ 200 partners
  - States registering boards
  - States and Municipalities Economic Departments
  - Professional Entities
- ◆ National Program of Fiscal Education (PNEF)



## Integration & cooperation with other public entities

➤ National Synchronized Register

➤ National SIMPLES



# Identifying & Registering SMEs



- Single data entry for business
- Only one identifier number
- Many public entities

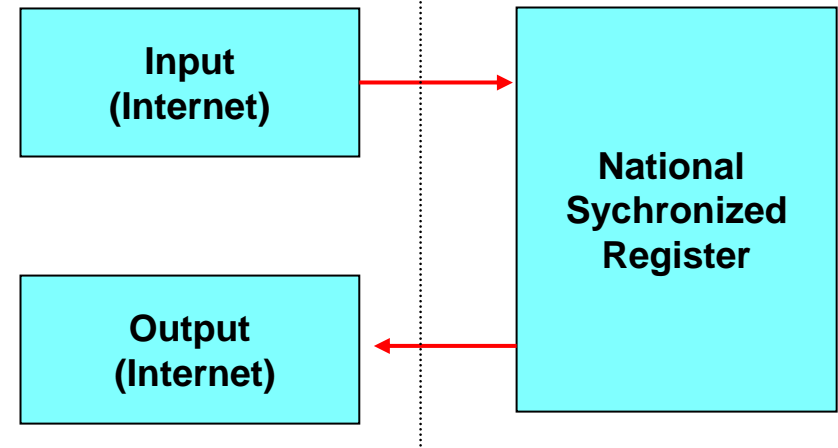

## SIMPLES

- A simplified tax rule by which Brazilian SME may make one monthly payment that replaces 8 taxes
- Created in 1996
- The bigger the business turnover, the higher the SIMPLES rates
- Criteria for acceptance is based on turnover

### General Rule

5 FEDERAL TAXES

+

SOCIAL

CONTRIBUTIONS

STATE TAX

1 MUNICIPAL DUTY

**SIMPLES**



## SIMPLES

### Objectives

- To reduce compliance costs for SME
- To encourage business registration
- To encourage formal jobs
- To simplify obligations
- To lower data processing costs
- To reduce administrative control costs for SME
- To improve control and also exchange of information among tax authorities of the 3 levels of government
- To provide a standard for internal operations



## SIMPLES Nacional

### - What is new after July 2007 ?

- Mandatory for States and Municipalities
- New rates
- More business activities allowed
- A Steering Committee was enacted with representatives from the tax administrations of the three levels of government
- The SIMPLES website



## SIMPLES

### Number of Business

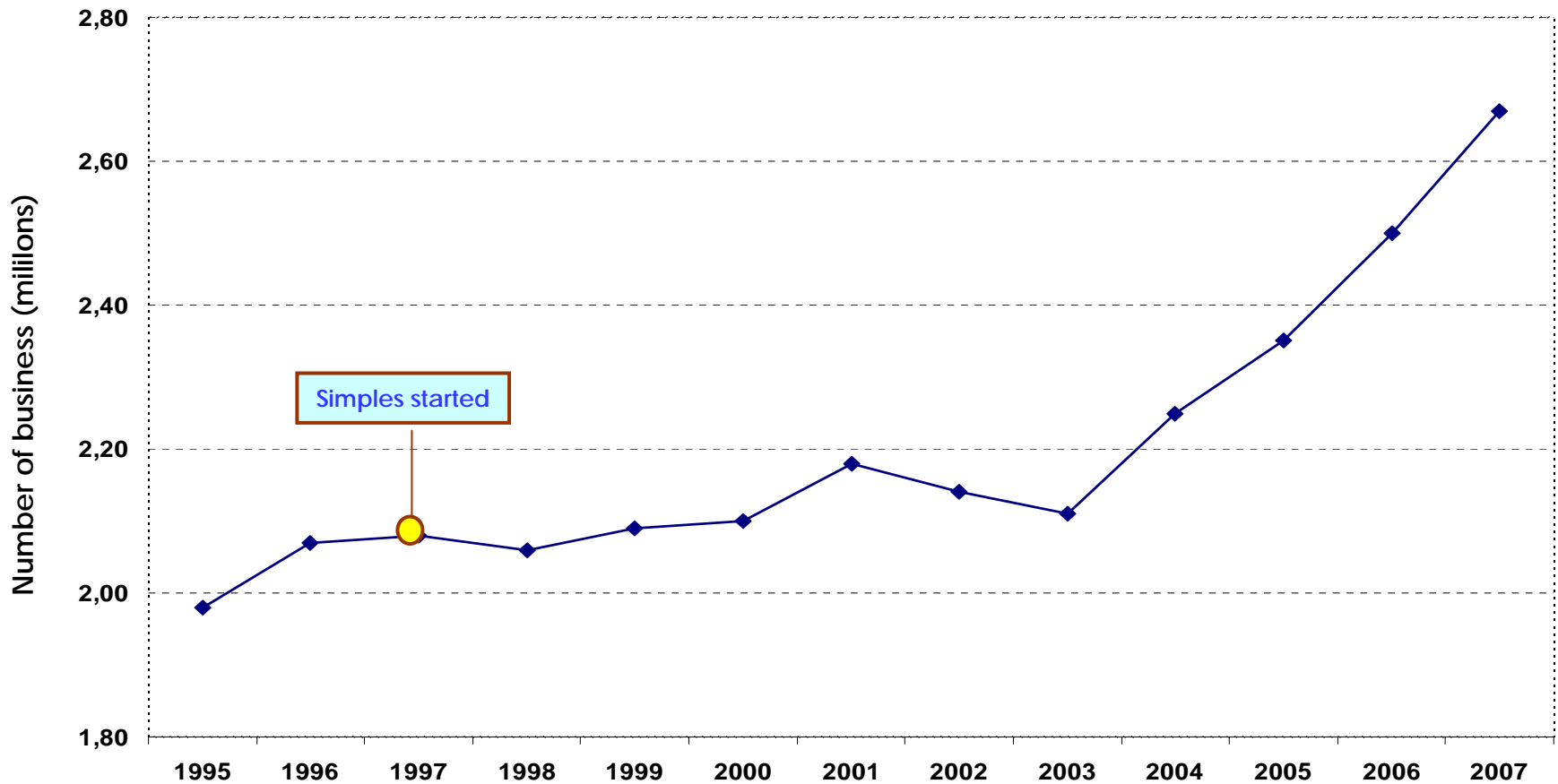

# Identifying & Registering SMEs

## SIMPLES

### Revenue Collected

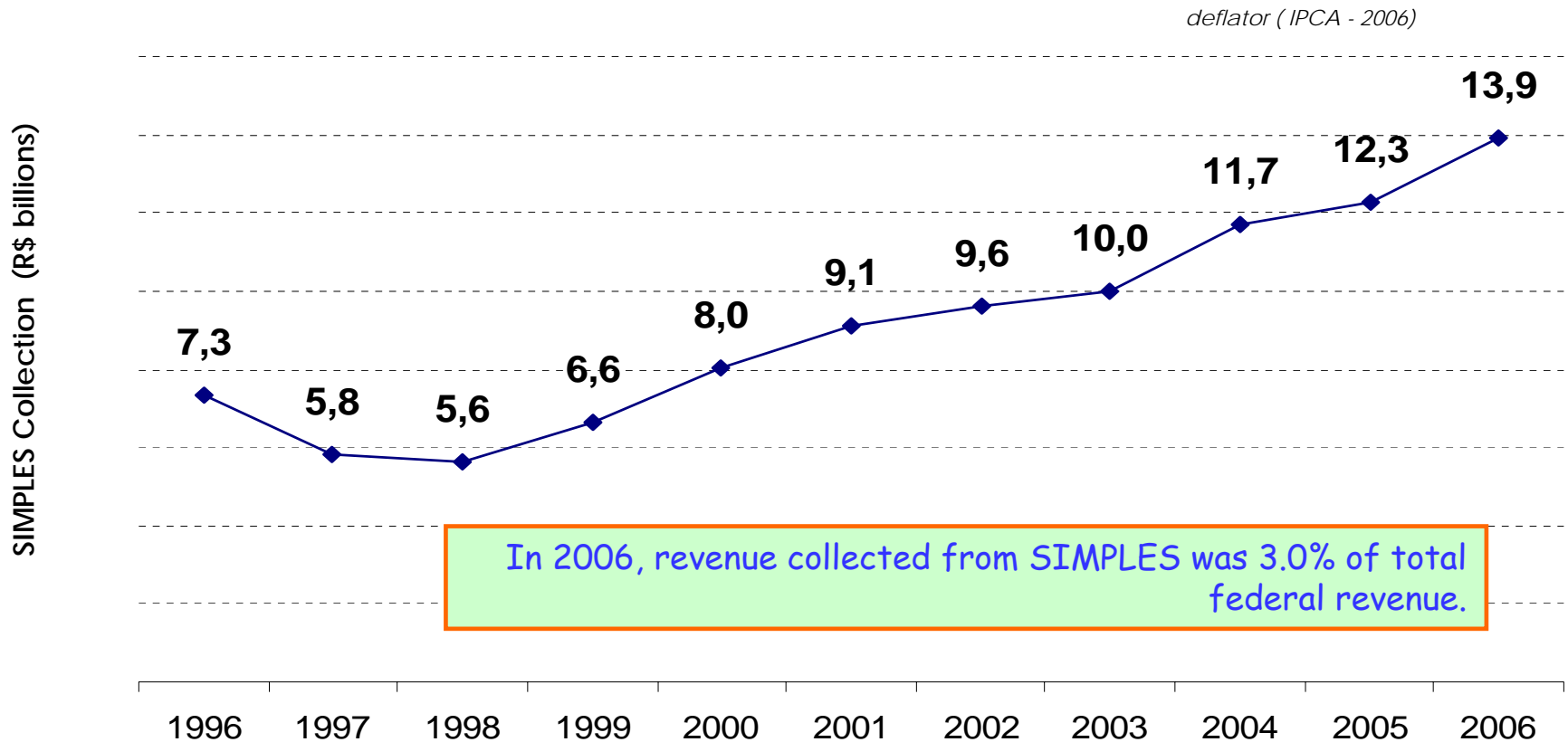

Source: RFB



## SIMPLES

### Jobs Formalization

- Just after SIMPLES was enacted, there was a significant increase in the number of formal jobs
- According to Ministry of Finance data, formal jobs in SME has increased beyond 500 thousand between 1996 & 1998
- In the same period, SME employees have increased their tax collection withheld at source by 45%
- Currently, the SME of SIMPLES employ 6.4 millions and this is 30% of employment in the formal sector



## Compliance Control

- ◆ Good use of information
- ◆ Enforcement



## Good use of Information

- ◆ Immovable property forms (DOI y Dimob)
- ◆ Credit card statements (Decred)
- ◆ Financial operations (CPMF)
- ◆ Withholding at source



# Reducing Informality

WITHHOLDING AT SOURCE - B2B (ACT 10.833/03 )  
DECEMBER/06 - deflator IPCA

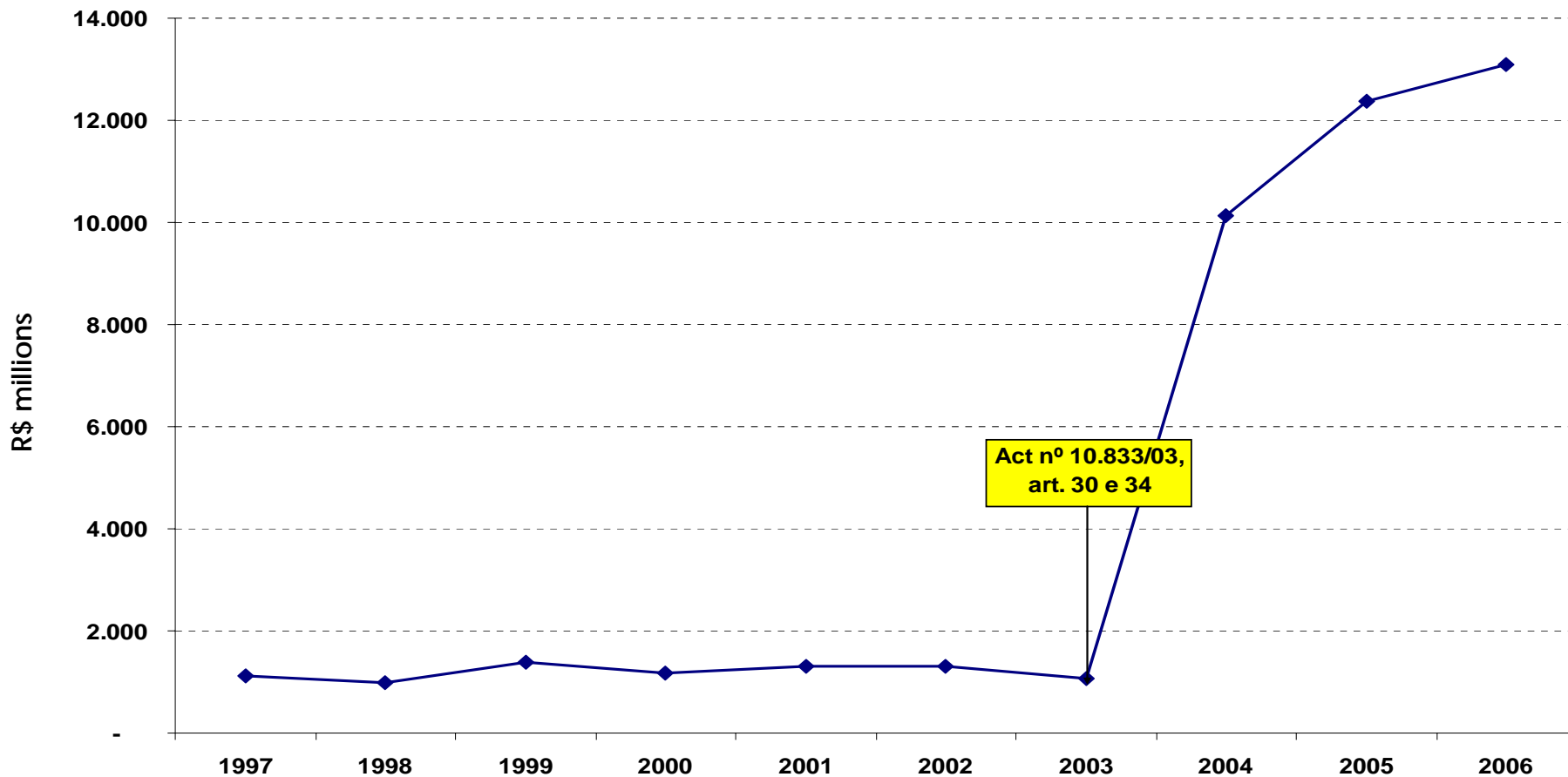

# Reducing Informality

## Enforcement



# Reducing Informality

- From 2002 to 2006, RFB examined 285 thousand SMEs resulting 91 billion of reais in tax overdue
- Many individuals were imprisoned in joint operations with the Federal Police, those facts calling the media's attention
- 100% growth in the collection of interest and fines after assessing and charging overdue tax debts
- Tax levy is increasing in real terms without changes in rates or in the number of taxes



## Conclusión

- SMEs face relatively higher barriers to formalization
- SMEs support from Government is guaranteed in the Brazilian Federal Constitution
- *Receita Federal do Brasil (RFB)* has a key role for the development and registration of SMEs by performing high quality services and by appropriate control
- Assistance aims to reduce compliance and administrative costs
- Compliance control of SMEs is based upon the massive use of ICT, integration with other public entities and strong enforcement measures





# Receita Federal

[www.receita.fazenda.gov.br](http://www.receita.fazenda.gov.br)

